PUDU MT1 Vac Operation Guide

Document Version: V5.0

Model: MTBC02

Copyright © 2026 Shenzhen Pudu Technology Co., Ltd. All rights reserved.

Without the express written consent of Shenzhen Pudu Technology Co., Ltd., no unit or individual may imitate, copy, transcribe or translate part or all of the contents of this operation guide without authorization, and shall not distribute it in any way (electronic, photocopying, recording, etc.) for profit. The product specifications and information mentioned in this operation guide are for reference only, and are subject to change without further notice. Unless otherwise specified, this operation guide is only used as a guide, and all statements made do not constitute any form of warranty.

Purpose





This manual introduces how to use and maintain the PUDU MT1 Vac. It is intended for users, sales personnel, technical support engineers, and installation and commissioning engineers.

Revision History

Date	Revision History
2026.02.27	Initial release

Symbol Conventions

The following symbols may appear in this manual, and their meanings are as follows.

Symbol	Description
 Danger	Indicates a high potential hazard that, if not avoided, will result in death or serious injury.
 Warning	Indicates a moderate or low potential hazard that, if not avoided, could result in minor injury to personnel, damage to the robot, etc.
 Caution	Indicates a potential risk that, if these texts are ignored, could result in damage to the robot, data loss, or unpredictable results.
 Notes	Indicates additional information to the main text, emphasizing and supplementing the main text.

Contents

PURPOSE	1
REVISION HISTORY	1

SYMBOL CONVENTIONS	1
CONTENTS	2
1、 INTENDED USE	5
2、 SAFETY INSTRUCTIONS	5
2.1 USAGE PRECAUTIONS	5
2.2 ENVIRONMENTAL PRECAUTIONS	6
2.3 POWER SUPPLY PRECAUTIONS.....	7
3、 PRODUCT COMPONENTS	8
3.1 PACKING LIST	8
3.2 APPEARANCE AND PARTS.....	9
3.3 PERFORMANCE PARAMETERS	11
4、 PRODUCT USAGE	12
4.1 POWER ON, POWER OFF, PAUSE, START	12
4.1.1 Power On, Power Off.....	12
4.1.2 Pause	13
4.1.3 Start	13
4.2 HANDLE USAGE	14
4.3 INSTALLATION AND REMOVAL OF DUST BAG AND DUSTBIN	15
4.4 WORK MODES.....	16
4.4.1 Manual Cleaning	16
4.4.2 Automatic Cleaning	16
4.4.3 Scheduled Task Settings	17
4.5 CLEANING MODES	18
4.6 ROBOT CHARGING	19
4.7 VIEWING DEVICE STATUS.....	19
4.8 SETTINGS	20
4.9 COMMON FUNCTIONS	21
5、 PRODUCT MAINTENANCE & TROUBLESHOOTING	26
5.1 DAILY CLEANING.....	26
5.1.1 Cleaning Sensors and the Underside of the Robot	26
5.1.2 Cleaning the Dustbox and Air Filter	27
5.1.3 Cleaning the Side Brush and Brush.....	28
5.2 CONSUMABLE REPLACEMENT	29
5.3 TROUBLESHOOTING	30
AFTER-SALES POLICY	30



1、 Intended Use



The PUDU MT1 Vac is an AI-powered, intelligent 3-in-1 cleaning robot (sweeping, vacuuming, and pushing) specifically designed for large-scale environments, featuring exceptional vacuuming capabilities. It efficiently meets the cleaning requirements of various carpets and hard floors, primarily serving indoor venues with strict cleanliness standards, such as airports, luxury hotels, banquet halls, and industrial environments. Through fast and high-efficiency cleaning, the MT1 Vac not only improves environmental hygiene quality but also helps customers significantly reduce costs and enhance operational efficiency.

2、 Safety Instructions

2.1 Usage Precautions

1. This product is a wheeled automatic cleaning robot, limited to use in flat indoor environments. Do not use it outdoors (such as open balconies), on rugged grounds (such as stairs), or in environments above 40°C or below -10°C.
2. Cannot be charged below zero degrees Celsius (the robot automatically protects and cannot be charged).
3. Charging in dynamic temperature environments (e.g., medium-temperature cold storage, working inside, charging outside the cold storage) requires corresponding software versions. If the robot enters the wrong position accidentally due to obstruction or other factors, please pause the task in time and push it to the correct route before continuing the task.
4. Do not drag the robot during operation. If you need to push or move the robot, please tap the screen to pause it first.
5. Do not push the robot in reverse while it is powered on.
6. Do not block the robot's sensors, otherwise it may cause abnormal movement or loss of positioning.
7. Do not pat the device or forcefully press/knock on the screen, otherwise it may cause damage to the device.
8. Do not place loads on the robot, do not place open flame stoves, and do not place any combustible solids, gases, or liquids.
9. Do not make temporary setting adjustments while the robot is moving. All operations should be carried out



after tapping the screen to pause the robot's driving.

10. Cleaning and maintenance work are prohibited while the machine is powered on and running.
11. Before use, please put away various wires on the ground in the environment to avoid dragging during the host's operation.
12. For safety, please ensure the robot runs at a speed of 1.2m/s or below. Playing and fighting in front of the robot is prohibited to avoid unnecessary injuries. The robot has an automatic obstacle avoidance function, but there are blind spots in recognition. Therefore, it is strictly prohibited to suddenly block the robot while it is traveling at high speed, otherwise it may cause safety accidents.
13. When transporting the robot, be sure to empty the trash in the dustbox. Tilting the machine is strictly prohibited during transportation, otherwise the body may be damaged.

2.2 Environmental Precautions

1. This robot is suitable for flat ground environments. It is not suitable for use in environments with steps, excessive slopes, or overly tight spaces.
2. It is not recommended to use the robot on heavily oil-stained floors.
3. Debris such as power cords scattered on the ground may trip or entangle the robot. Please remove them before use.
4. When using this product with obvious ground protrusions such as thresholds, please ensure the height of the protrusions is within 20mm.
5. The optimal passage width for the robot should be greater than 75 cm; for long corridors, a width greater than 80 cm is recommended for the best fluid movement.



Ground Conditions	Illustration
<p>The maximum climbing angle designed for the robot is 8° (in non-cleaning status). To prevent potential risks caused by the robot slipping backwards, you should avoid pausing the machine while the robot is going uphill.</p>	 <p>An illustration of the PUDU MT1 Vcc robot on a grey incline. A curved arrow at the bottom right indicates the angle of the incline is 8°.</p>
<p>The robot only supports cleaning operations on flat surfaces. Do NOT perform cleaning tasks on visible slopes exceeding 3°.</p>	 <p>An illustration of the PUDU MT1 Vcc robot on a grey incline. A curved arrow at the bottom right indicates the angle of the incline is 3°.</p>
<p>Environments with solid black surfaces (e.g., baseboards), mirrored surfaces (e.g., walls), or full transparency at a height of 14–22 cm may interfere with lidar reflections, causing abnormal navigation. These scenarios require assessment by technical support and may necessitate site modifications, such as applying stickers, to ensure proper reflection.</p>	

2.3 Power Supply Precautions

1. Fully charge the robot to 100% before its first use.
2. To ensure operational efficiency and battery longevity, always maintain the battery level above 10%.
3. When the battery drops below 10%, the robot enters a low-battery state and must be charged as soon as possible.
4. When the battery drops below 2%, it enters battery protection mode; the robot will be unable to perform tasks and must be recharged before use.

3、 Product Components

3.1 Packing List

Main unit x 1, Charger x 1, Sweeping side brush x 2, Sweeping roller brush x 1, "PUDU MT1 Vac User Manual" x 1, Certificate of Conformity x 1, Positioning code x 1, Warning flagpole x 1, Dust Bag x6, HEPA Filter x4, Dust Mop Cloth x2.

3.2 Appearance and Parts

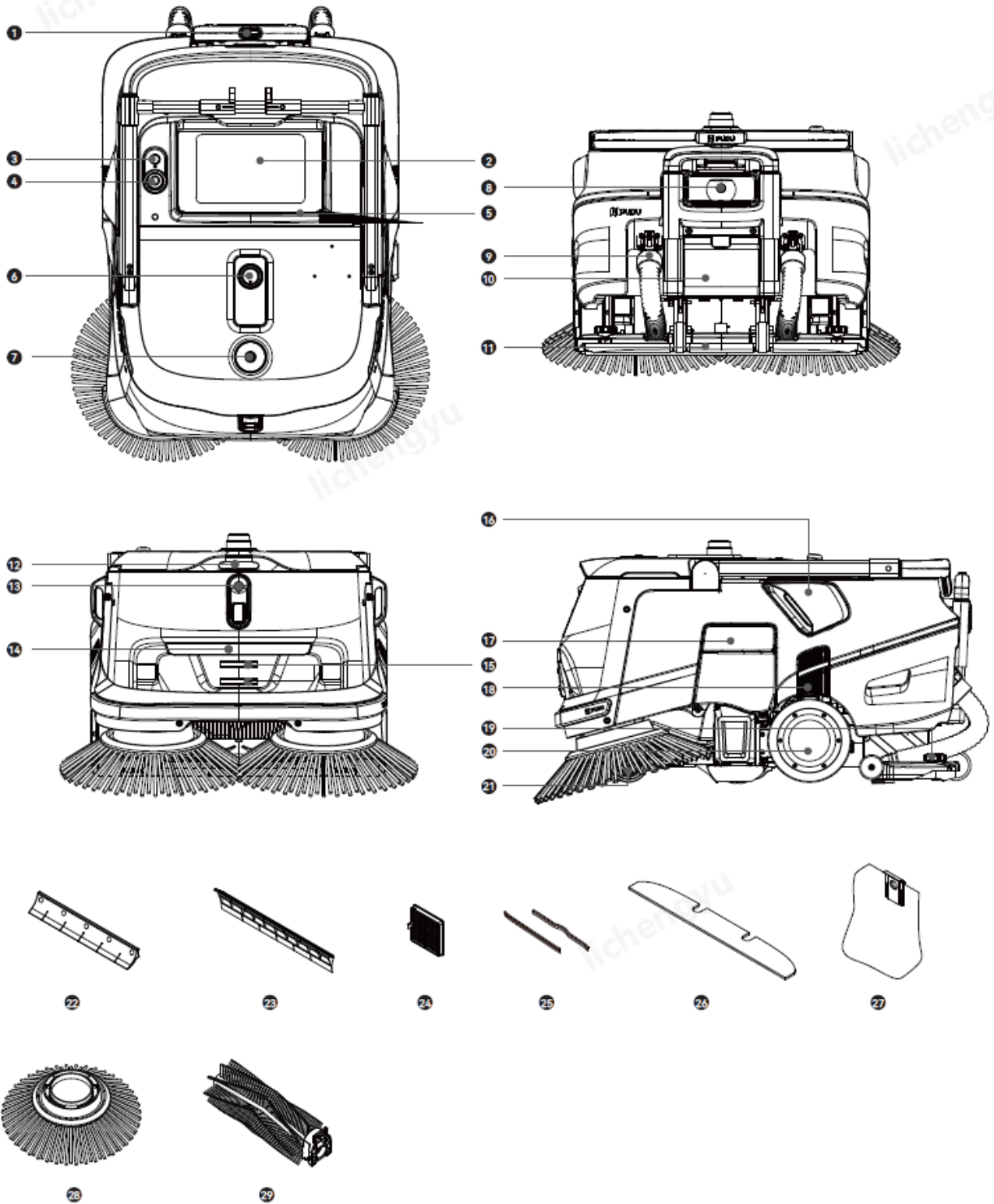

No.	Description
1	Handlebar / Handrail
2	LCD Screen
3	Power Button (On/Off)
4	Emergency Stop Button
5	Screen Protector / Screen Cover
6	LiDAR
7	VSLAM Camera
8	RGB Camera
9	Vacuum Hose (Quick-release)
10	Squeegee Height Adjustment Lever (Built-in)
11	2-in-1 Vacuum & Dust Mop Squeegee
12	RGB-D
13	RGB Camera
14	Fill Light
15	Charging Electrode / Charging Contact
16	RGB-D
17	Charging Port Cover / Flip Cover
18	Fan Exhaust Cover Plate
19	Dust Mop Plate Release Knob
20	Driving Wheel
21	Universal Wheel / Caster
22	Dustbin Rubber Strip
23	Roller Brush Compartment Front Rubber Strip
24	HEPA Filter (Non-washable)
25	Suction Port Rubber Strip
26	Dust Mop Cloth
27	Dust Bag (Non-washable)
28	Sweeping Side Brush
29	Sweeping Roller Brush

3.3 Performance Parameters

Product Features	Description
Product Model	MTBC02
Working Voltage	DC 23V~29.2V
Power Input	AC 100 V ~ 240 V, 50/60 Hz
Power Output	Max: 29.2 V, 20 A
Battery Capacity	60Ah
Charging Time	Approx. 3.5h
Runtime / Battery Life*	3-6.5h
Cleaning Capacity	Paper scraps, wood chips, dust, and other debris
Net Weight	Approx. 75kg
Dimensions	840600490mm
Housing Material	PC+ABS
Screen Specifications	10.1-inch LCD Screen
Navigation Method	LiDAR and Vision Fusion Positioning
Cruising Speed	0.2 m/s ~ 1.2 m/s (Adjustable)
Operating Noise	<65 dB (A) in Noise Reduction Mode
Maximum Vacuuming Width	55cm
Minimum Passage Width	75 cm
Maximum Obstacle Clearance Height	20 mm
Maximum Climbing Angle	8°
Maximum Gap Width	30mm
Cleaning Width (including side brushes)	Approx. 70cm
Dust Bag Capacity	14L (7L*2)

Dustbin Capacity	6L
Operating System	Android
Communication Network	Supports 4G, Wi-Fi, Bluetooth, Lora or 2.4G (Optional)
Mobile App	Supported
Operation Mode	Manual Mode, Auto Mode
Automatic Charging	Supported (Charging station required)
Working Environment	Temp: -10°C ~ 40 °C; Humidity: ≤ 90% RH
Charging Environment	Temp: 0°C ~ 40 °C; Humidity: ≤ 90% RH
Storage Environment	Temp: -20 °C ~ 70 °C; Humidity: ≤ 90% RH
Operating Altitude	< 2000 m
Applicable Flooring	Polished concrete, epoxy resin, rubber, regular masonry, ceramic tile, and other hardened floors; short-pile carpets, industrial carpets, and other carpeted surfaces
Protection Rating / IP Rating	IPX3

(* The battery life of each cleaning mode is calculated under the standard gear, with the battery level from 100% to 10%.)

4、Product Usage

4.1 Power On, Power Off, Pause, Start

4.1.1 Power On, Power Off

Power On:

Press and hold the power button for about 3 seconds, the bottom strip light will show blue.



Power Off, there are 2 methods:

- 1) Press and hold the power button for about 10 seconds to start the power off operation. A black screen indicates successful power off.
- 2) Tap "More" on the home page to select "Power Off" or restart the robot.

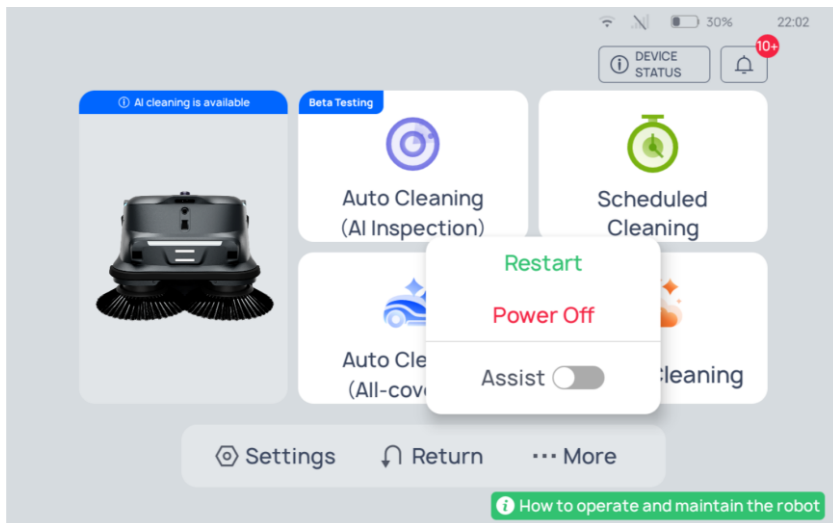

4.1.2 Pause

During the robot's Auto-Cleaning operation, touch to wake up the screen, and tap the Pause button to stop the robot.

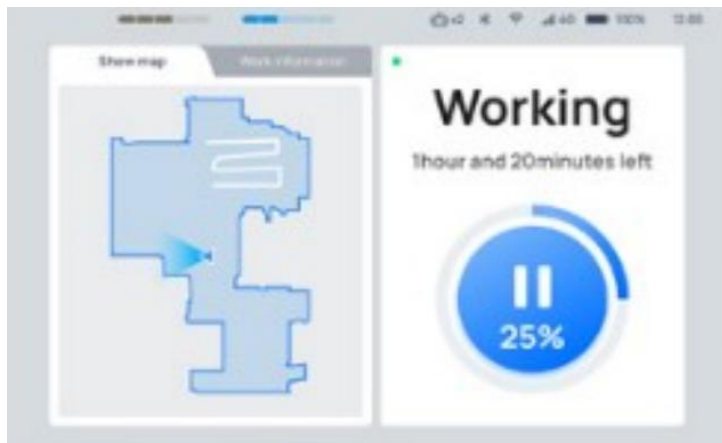

4.1.3 Start

If you need to continue running, tap the Start button on the screen, and the robot will resume the task.

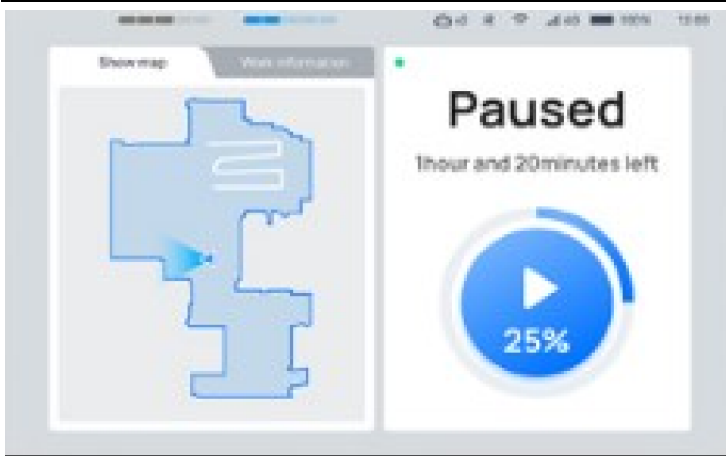

4.2 Handle Usage

When you need to push the robot, please lift the handrail.

When the robot is idle or operating automatically, please put the handrail down.

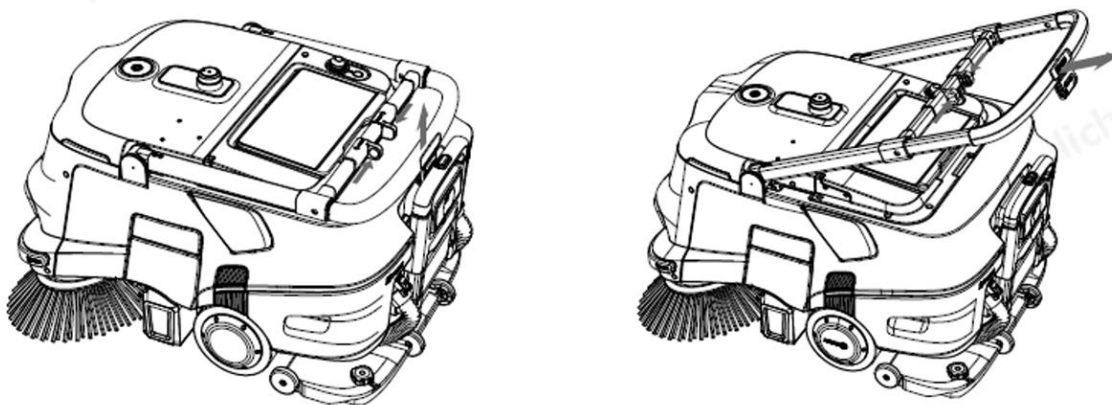
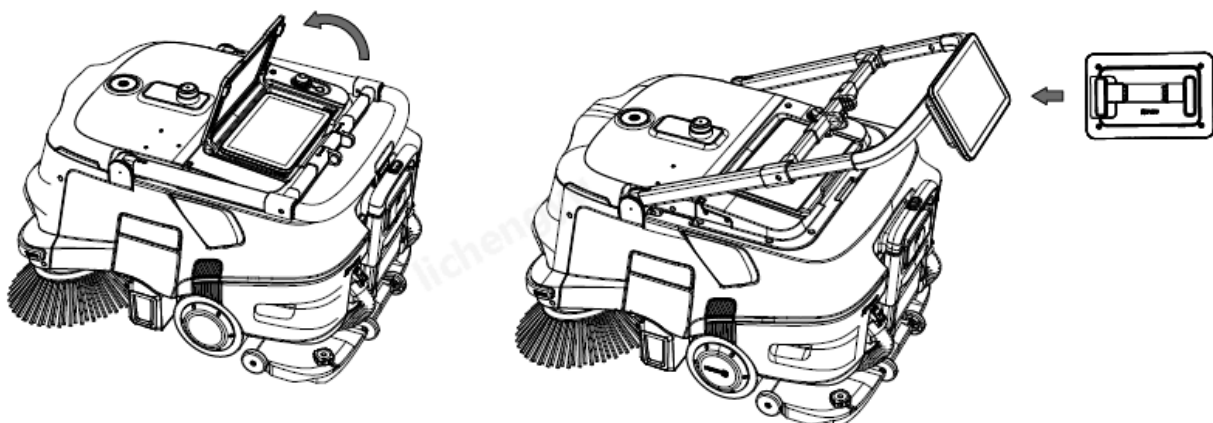

Illustration (How to Unlock the Handrail)

When you need to operate the screen, you can open the protective cover and operate it directly, or detach the screen from the top of the body and hold it or fix it on the handrail to operate.



* The robot handle and screen feature a detachable design.

4.3 Installation and Removal of Dust Bag and Dustbin

Unlock and pull out the rear dust module (in the direction shown in the illustration)

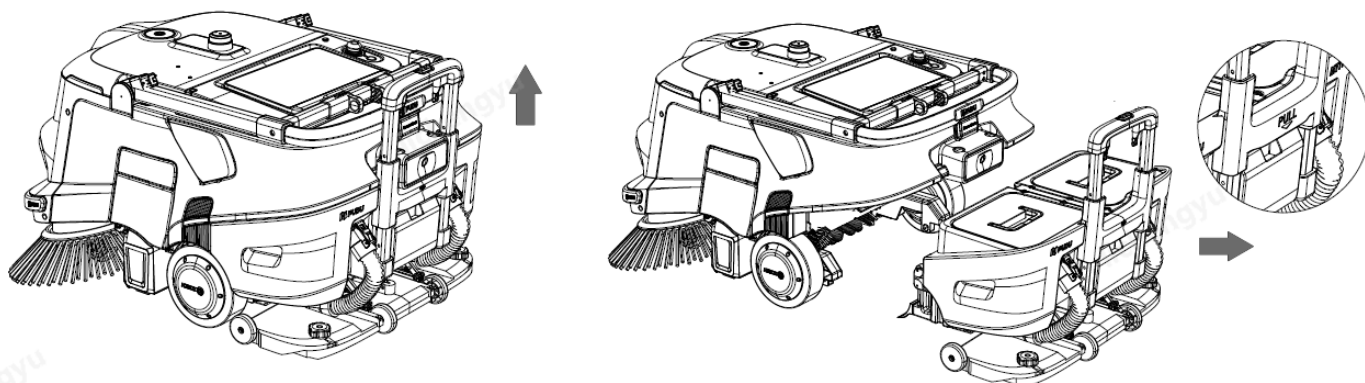

Open the dust bag compartment cover and pull out the dust bag (in the direction shown in the illustration)

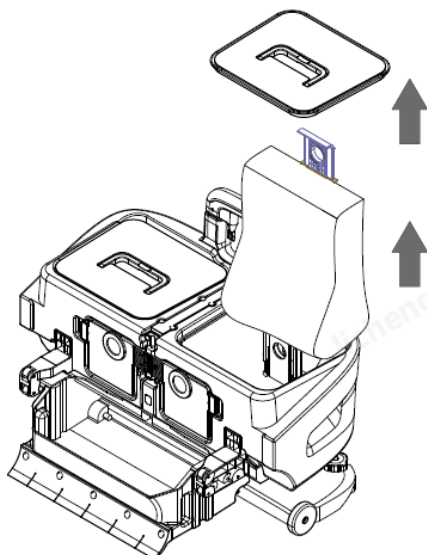

Pull out the dustbin (in the direction shown in the illustration)

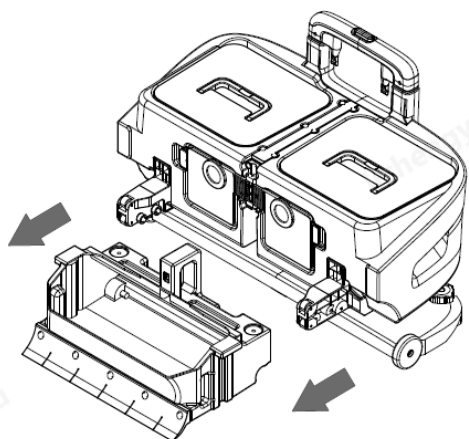

4.4 Work Modes

4.4.1 Manual Cleaning

After clicking "Manual Cleaning" on the home page, adjust to the desired cleaning level and click "Start Cleaning" to push the robot for the cleaning task (Note: During manual cleaning, the handlebar must be raised, the screen fixed on the handlebar, and then the robot pushed to clean).

Select the appropriate preset cleaning scenario based on the site conditions without manually adjusting cleaning parameters; on the task editing page, click cleaning parameters and select "Special Scenarios."

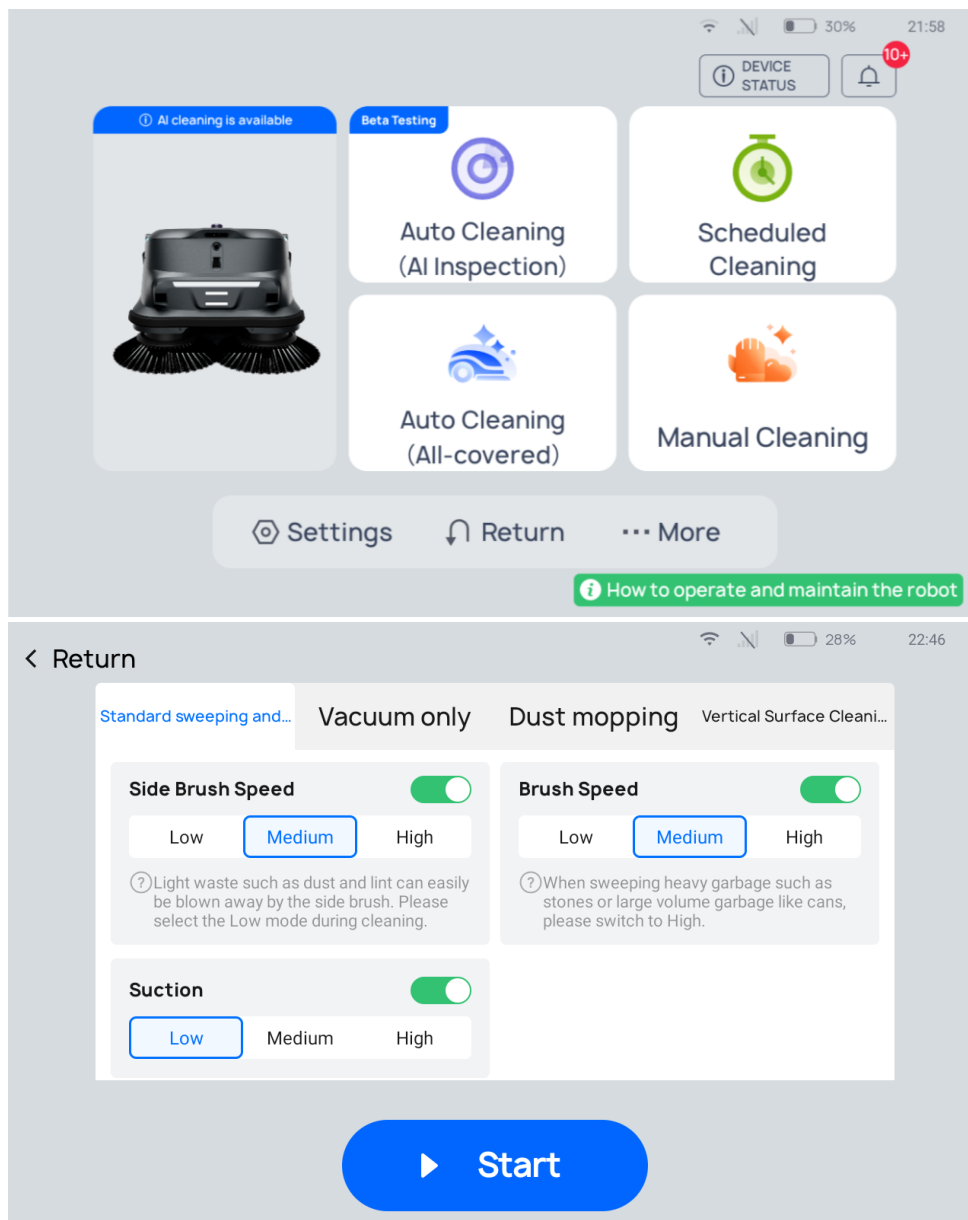

4.4.2 Automatic Cleaning

Before starting an automatic cleaning task, ensure the robot is powered on and positioned directly below or in front of the visual marker (depending on the marker's placement) to ensure successful positioning at

the starting point.



After clicking "Automatic Cleaning" on the homepage, select the cleaning task to be executed (pre-configured by delivery personnel). If no selection is made, the default task will be executed. Click "Start Cleaning" to begin the task. (Note: For automatic cleaning, the handle must be lowered and the screen returned to the screen compartment; otherwise, the task cannot start normally.)

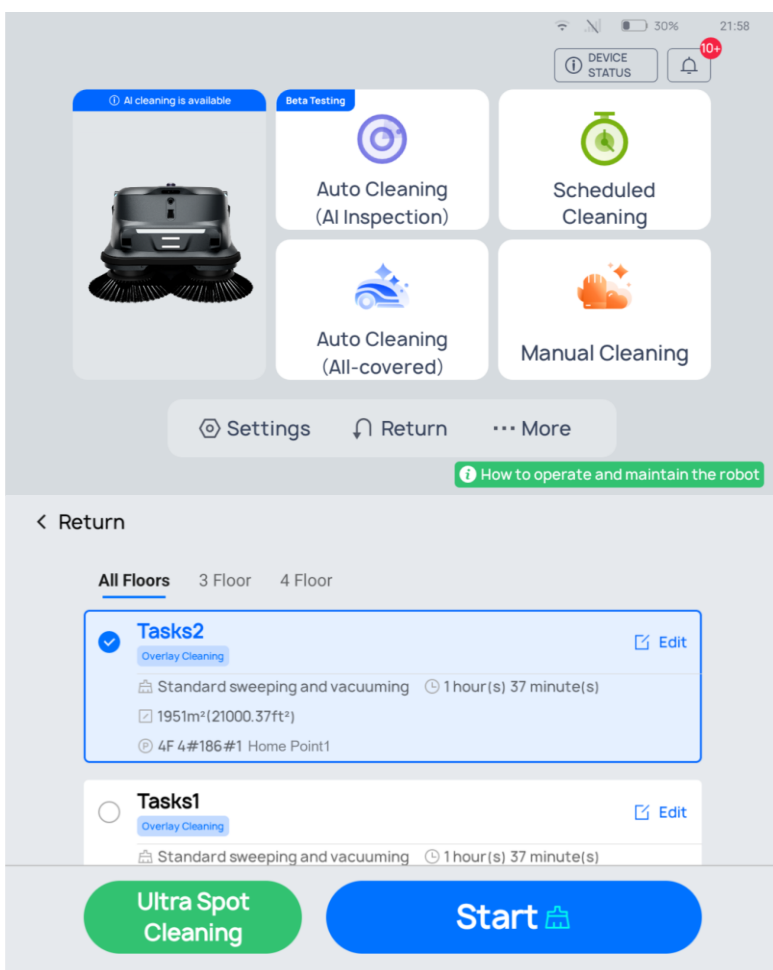

4.4.3 Scheduled Task Settings

The robot supports scheduled task settings. Once configured, the robot will automatically execute tasks at the set time, provided that positioning is normal and the battery level is sufficient.

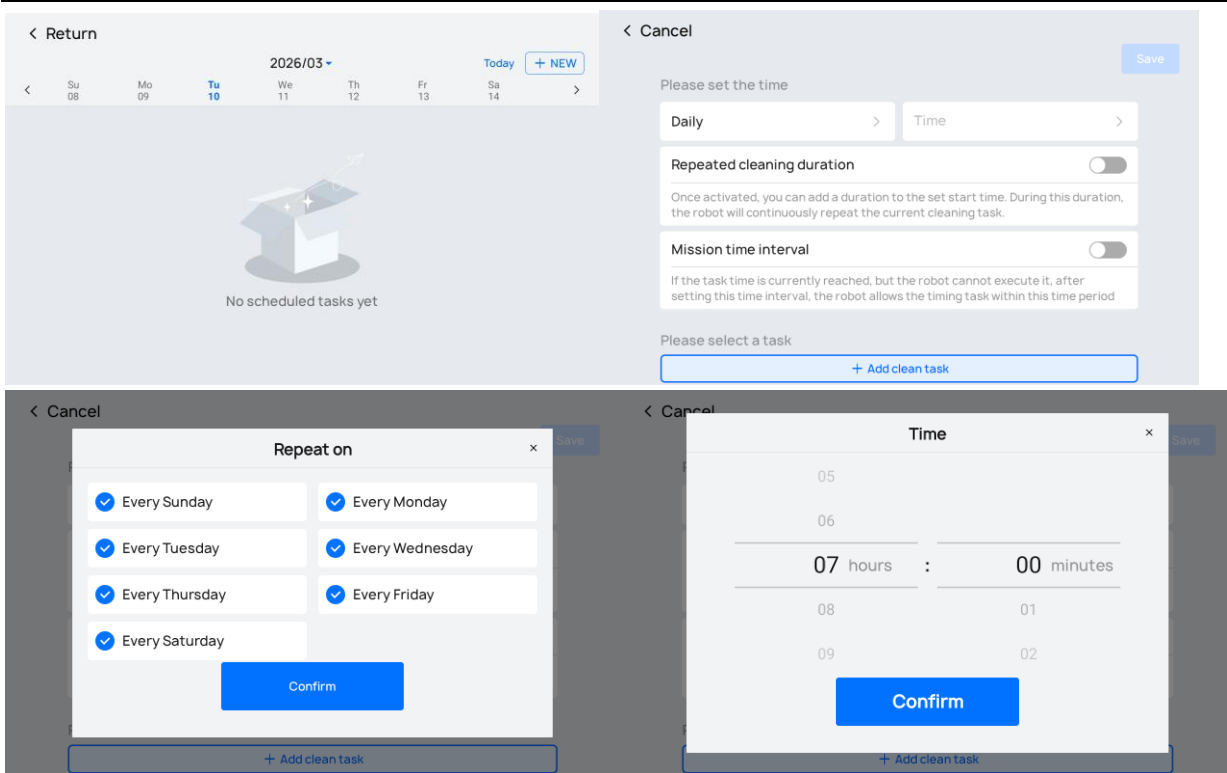

4.5 Cleaning Modes

The PUDU MT1 Vac is an AI-powered, intelligent 3-in-1 cleaning robot (sweeping, vacuuming, and pushing) designed for large-scale environments, featuring exceptional vacuuming capabilities.

Before cleaning, please ensure that the corresponding cleaning components are installed:

1. Side Brush * 2
2. Roller Brush * 1
3. Dust Bag * 2
4. HEPA Filter * 2



4.6 Robot Charging

MT1 Vac supports both manual and automatic charging.

Charging Method	
<p>Manual Charging</p> <p>Connect the robot's charging interface to the charging cable. Ensure the body's charging port is connected to the charging cable. If successful, the robot will prompt that it is charging.</p>	
<p>Automatic Charging</p> <p>The robot supports automatic charging, which requires the optional purchase and installation of a workstation or charging pile, deployed according to the corresponding equipment's instructions. Once deployed, the robot can perform fully autonomous recharging throughout the entire process.</p>	 <p data-bbox="730 1182 1305 1220">Robot docking with the charging station.</p>

Charing Page

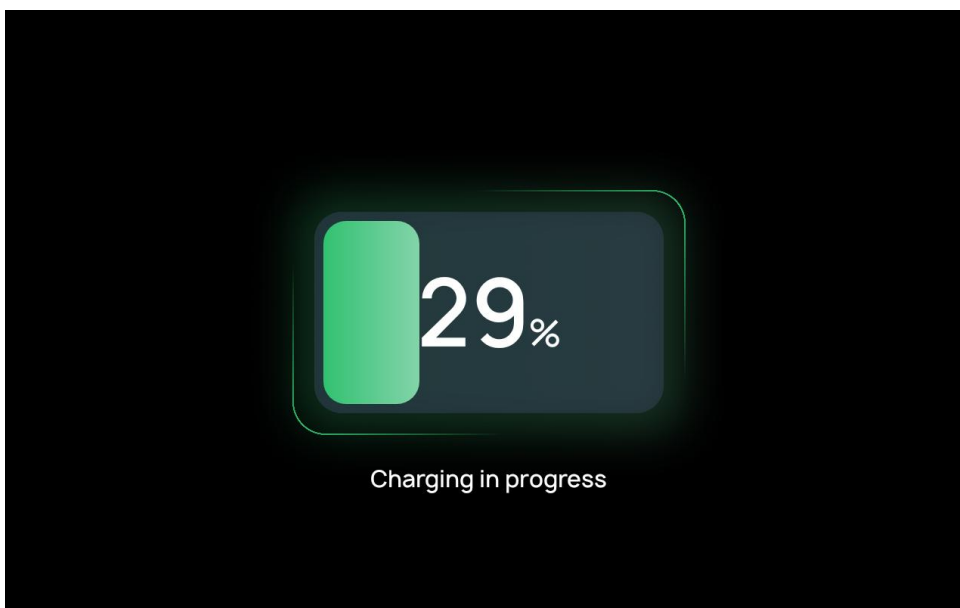

4.7 Viewing Device Status

Tap "Device Status" on the home page to enter the Device Status page.

On this page, you can check the robot's battery level and the remaining usage time of the corresponding consumables.

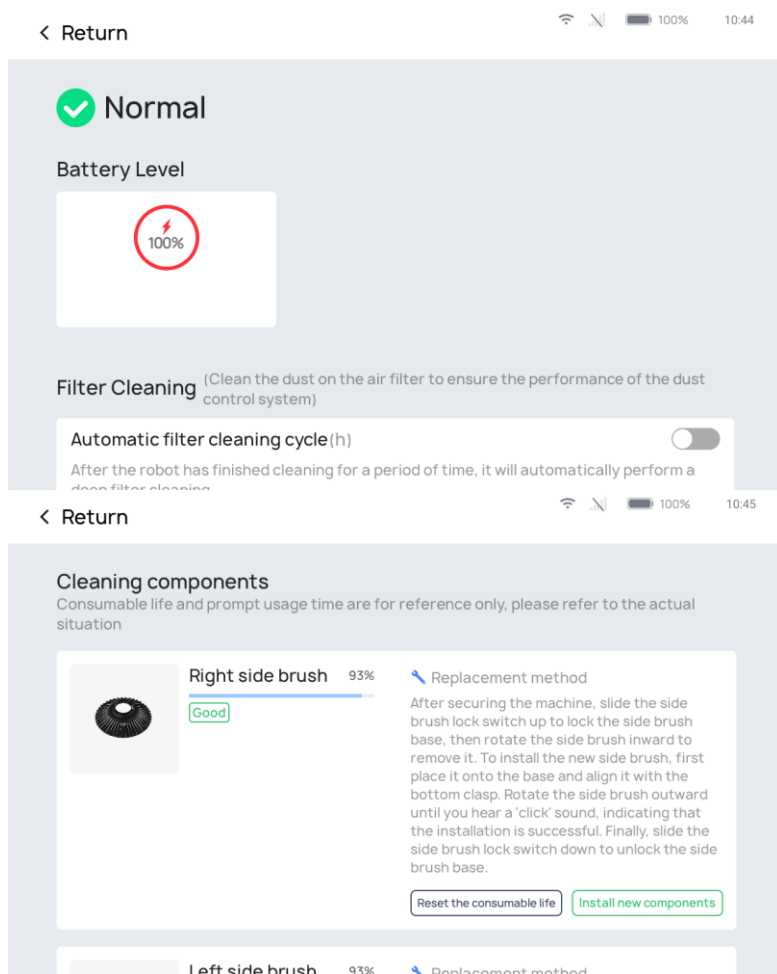

4.8 Settings

Settable items include the following:

Settings Item	Description
Task Management	Add, modify, and delete cleaning tasks.
Cleaning Report	View records of the robot's past cleaning reports.
Network	Configure network settings and connections.
Map	Create new maps, edit existing maps, etc.
Language	Select the corresponding national language.
Version Upgrade	Check for the latest software version upgrades.
Speed	Set speeds for different cleaning modes; default speed is 0.5 m/s.
Screen Lock Protection	Enable or disable screen lock; modify screen lock password and duration.
Debugging	Adjust internal parameters (accessible only to technical support personnel). The company assumes no responsibility for accidents caused by unauthorized

	operation.
Voice / Audio	Enable or disable voice broadcasts during cleaning; configure content and volume.
Time	Set the robot's system time.
Version Upgrade	Display and click to update the robot's software version.
Debugging	Adjust internal parameters (accessible only to technical support personnel). The company assumes no responsibility for accidents caused by unauthorized operation.
Others	Other robot settings.

4.9 Common Functions

4.9.1 Cleaning Task Settings

01 Confirm the minimum sum of length and width for RGBD obstacle determination

Based on the site conditions, confirm the sum of the height of common debris and the length and width of low obstacles in the site to ensure that larger debris is not falsely detected as an obstacle.

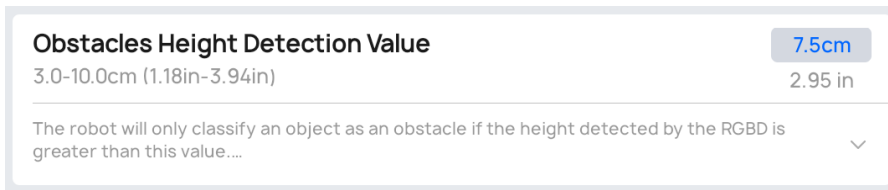

02 Select maintenance point

Add maintenance points during mapping, and select them when editing tasks. After setting, when the robot encounters exceptions or errors where it cannot continue cleaning but can move normally, it can go to the maintenance point automatically and wait for manual assistance.

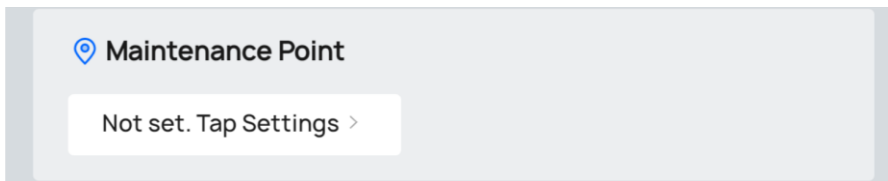

03 Sleep time period

Supports configuring sleep time on the robot end by date. Scheduled tasks set within the sleep time will not start automatically. Also supports batch setting of sleep time for robots in the same store on Pudulink and merchant platforms.

< Return

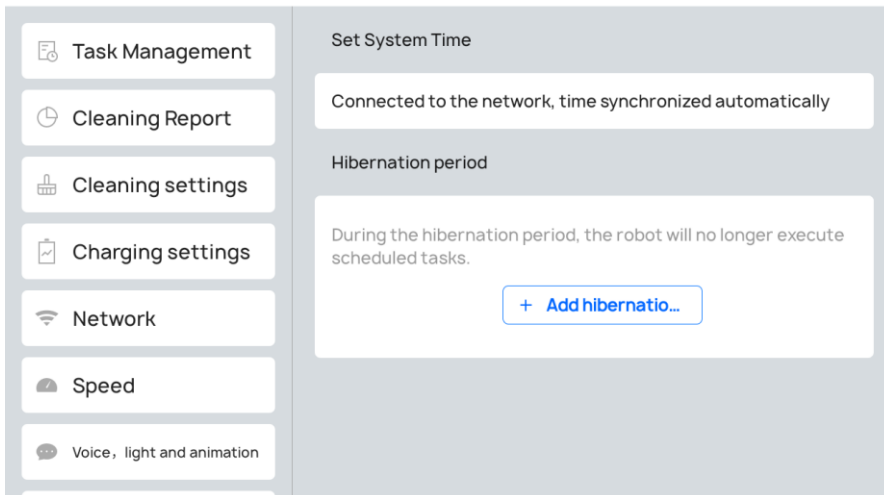

04 AI Cleaning

(1) Supports recognition of debris and stains with automatic adjustment of cleaning mechanism parameters. In patrol cleaning mode, it supports proactive navigation to identified debris for cleaning; specific types of debris and stains for proactive recognition can be selected from a list.

(2) Supports obstacle recognition and avoidance; specific obstacle types for avoidance can be selected from a list.

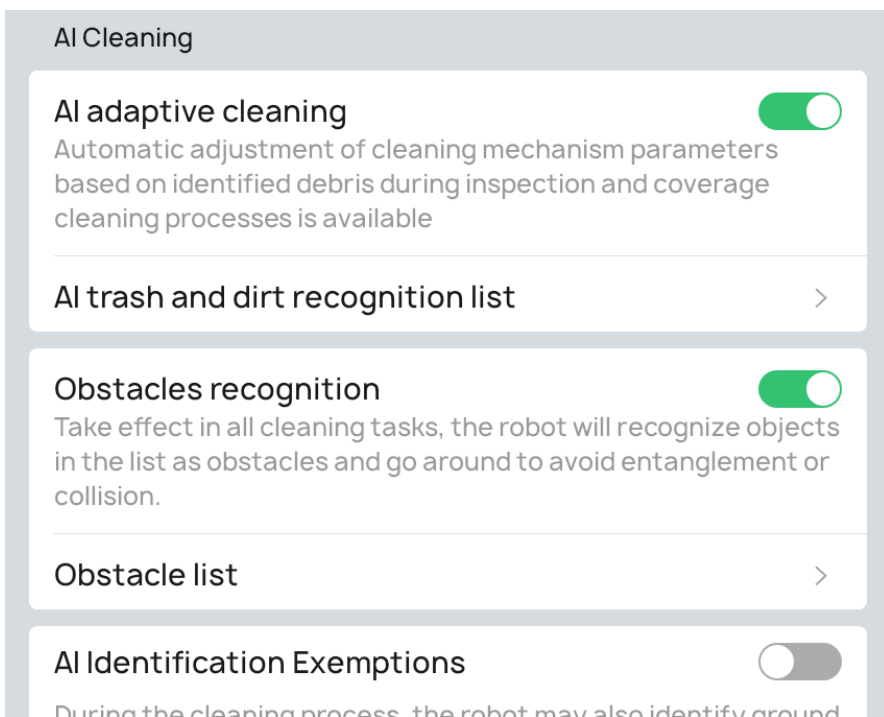







< Return

AI trash and dirt recognition list

Save

Once selected, this type of waste will be identified and cleaned during inspections. If there are frequently occurring types of waste in your area that are not listed, we welcome you to provide feedback to the regional agent.





 White paper <input type="checkbox"/> <input checked="" type="checkbox"/>	 Paper box fragments <input type="checkbox"/> <input checked="" type="checkbox"/>
 Plastic film <input type="checkbox"/> <input checked="" type="checkbox"/>	 Beverage bottle <input type="checkbox"/> <input checked="" type="checkbox"/>
 Paper food containers <input type="checkbox"/> <input checked="" type="checkbox"/>	 Leaf <input type="checkbox"/> <input checked="" type="checkbox"/>

< Return

Obstacle list

Save

Effective during cleaning tasks and inspection cleaning tasks, the system will identify obstacles and navigate around them to avoid entanglement or collisions. If there are frequently occurring types of obstacles in your area that are not listed, feel free to provide feedback to your regional agent, and we will consider whether to add these types.

 Cable <input type="checkbox"/> <input type="checkbox"/>	 Shoes <input type="checkbox"/> <input checked="" type="checkbox"/>
 Floor mat <input type="checkbox"/> <input checked="" type="checkbox"/>	 Base <input type="checkbox"/> <input checked="" type="checkbox"/>

05 Ultra Spot Clean

Supports Ultra Spot Clean for automated tasks. Based on debris/stain recognition heatmap data from the task, it performs high-speed cleaning in areas with a higher probability of generating waste.

< Return

All Floors 3 Floor 4 Floor

Tasks2

Overlay Cleaning

Edit

Standard sweeping and vacuuming 1 hour(s) 37 minute(s)

1951m²(21000.37ft²)

4F 4#186#1 Home Point1

Tasks1

Overlay Cleaning

Edit

Standard sweeping and vacuuming 1 hour(s) 37 minute(s)

Ultra Spot
Cleaning

Start 

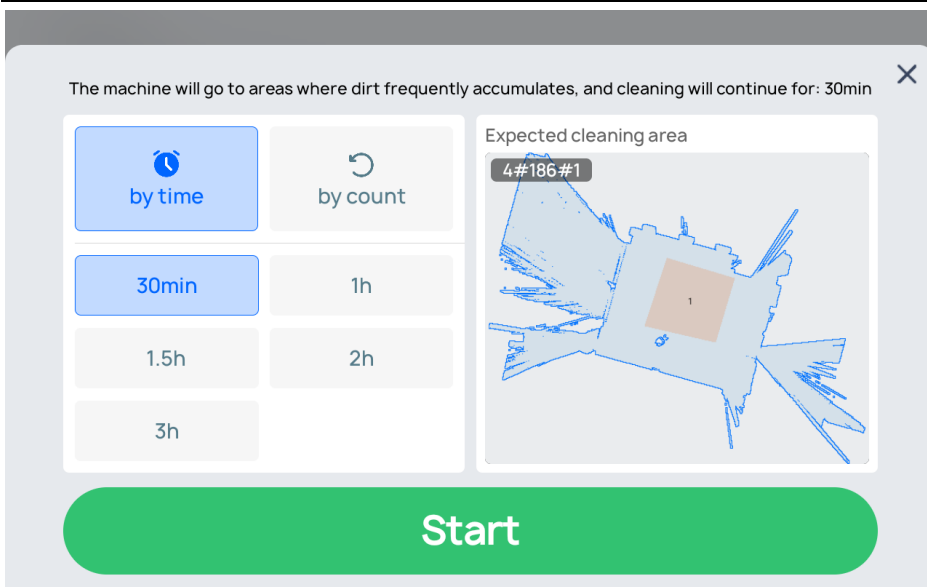

06 AI Auto/Manual Exemption

Supports "exemption" processing for floor patterns or designs prone to being misidentified as stains through two methods: manual validation or automatic learning. Once exempted, the robot will no longer trigger false identifications at that location in subsequent cleaning tasks.

AI Identification Exemptions

During the cleaning process, the robot may also identify ground wear, markings, decorations, etc. as dirt. After turning on this function, the targets that have been repeatedly identified as dirty but cannot be cleaned will be automatically exempted. The spot-cleaning and AI adaptive adjustment of cleaning parameters functions will not take effect on exempted targets.

Manual Exemption [>](#)

Exempting misidentified trash and obstacles will allow the robot to automatically ignore them during subsequent cleaning, making the cleaning process smoother.

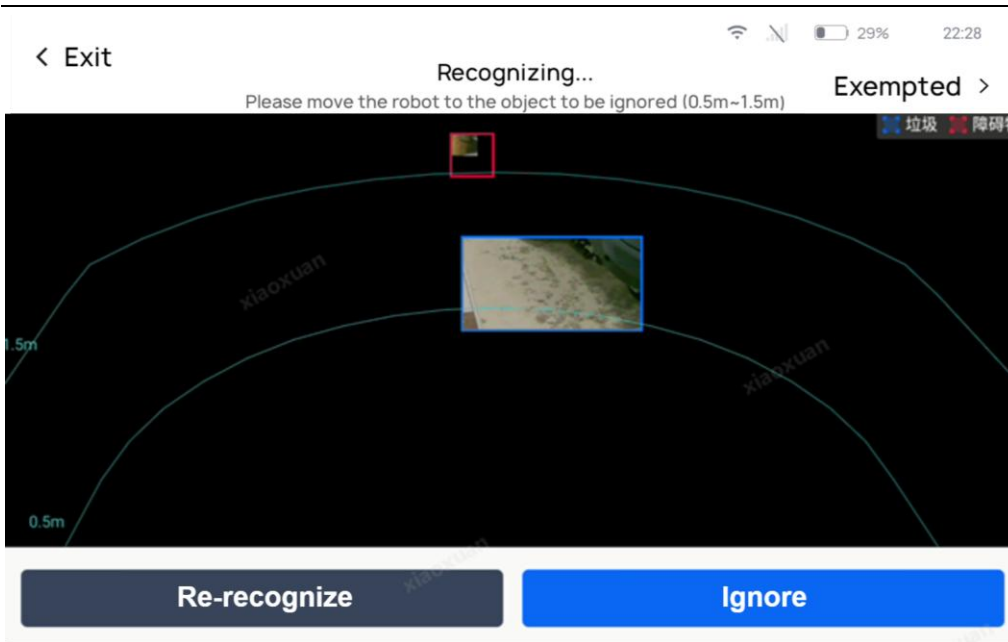

4.9.2 Product Interaction Settings

01 Multi-language Switching

Switch the language of the operating system



02 Metric and Imperial Unit Switching

When enabled, imperial units will be displayed

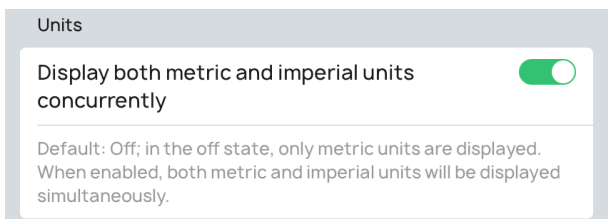

03 Play voice and music during operation

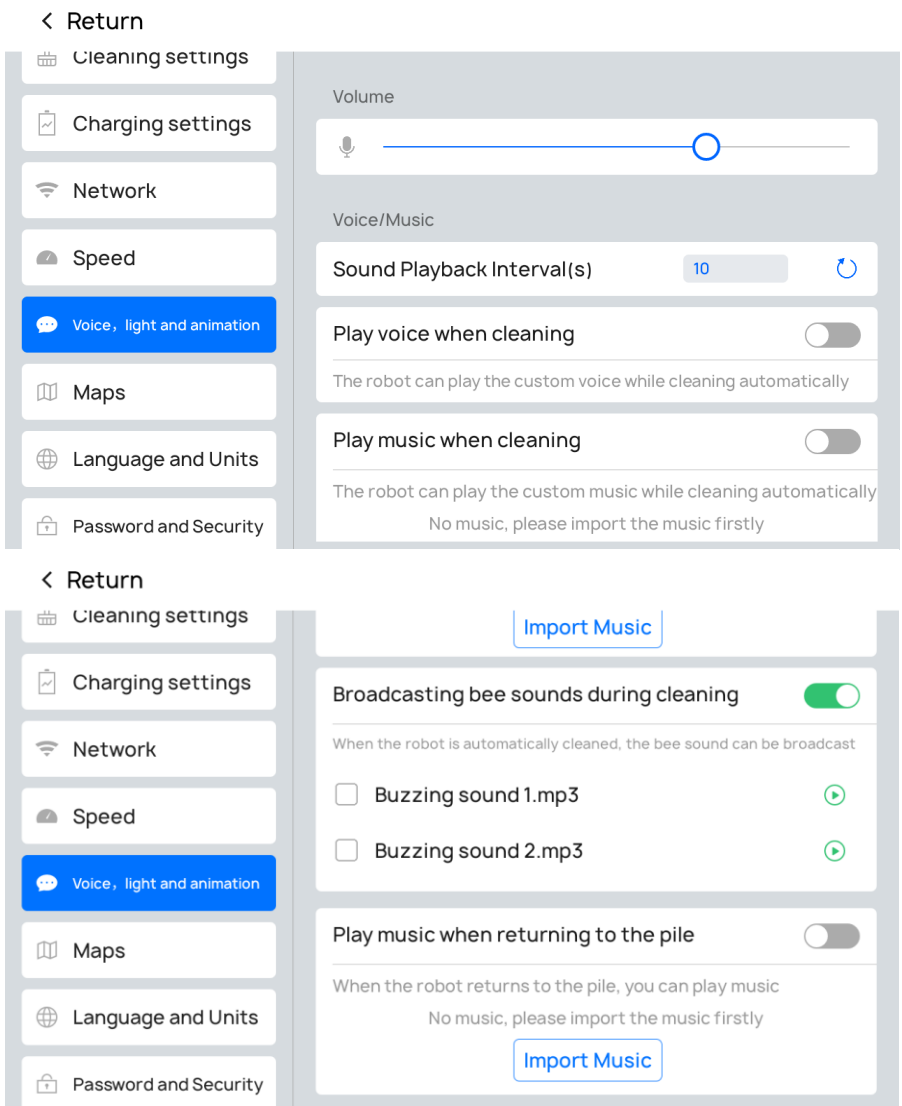

5、Product Maintenance & Troubleshooting

5.1 Daily Cleaning

5.1.1 Cleaning Sensors and the Underside of the Robot

Sensors are the robot's eyes. If they are obscured by dust, the robot will clean blindly; therefore, regular cleaning is required.

Cleaning Method	Wipe with a soft, clean cloth
Period	3-5 weeks

Body Sensor Diagram



5.1.2 Cleaning the Dustbox and Air Filter

Accumulation of garbage and dust can breed bacteria and affect cleaning effectiveness. Please clean it in time.

<p>Cleaning Method</p>	<ol style="list-style-type: none"> 1. Dustbox: Take out the dustbox to empty the garbage when it is full or regularly. 2. Air Filter: Use the dust scraping handle for daily cleaning. Put a garbage bag over it and pat it gently on a regular basis. Replace it directly if it is too dirty. Washing with water is not recommended. 3. HEPA Filter: Remove and replace regularly; non-washable;
<p>Period</p>	<p>Clean every 2 days, or clean once or multiple times a day depending on the degree of dirt.</p>
<p>Cleaning Illustration</p>	<p>Dustbox</p> <p>Dust Bag</p>



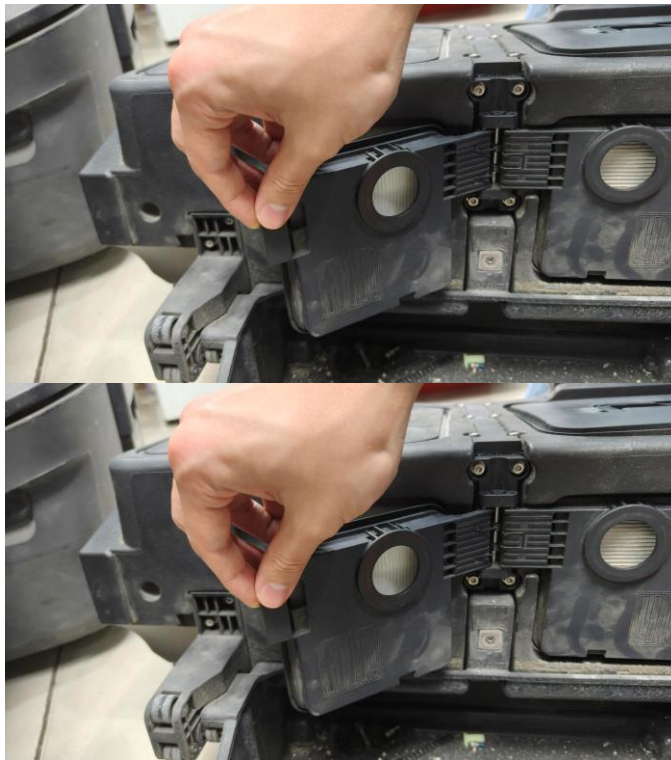

High-efficiency Particulate Air (HEPA) Filter







5.1.3 Cleaning the Side Brush and Brush

Hair and fine fabrics will entangle on the side brush and brush during operation. Failure to clean them for a long time will affect the cleaning effectiveness and even the service life of the motor.

Cleaning Method	Use a brush or hands to clean the side brush and brush, and remove tangles.
Period	Clean every 2 days, or clean once or multiple times a day depending on the degree of dirt.
Cleaning Illustration	<p>Side Brush Cleaning</p> 
	<p>Roller Brush Cleaning</p> 

5.2 Consumable Replacement

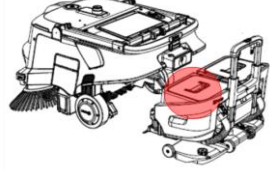
Part Illustration	Location	Part Name	Maintenance Method	Maintenance Period
		Side Brush	Clean	1 time/day
			Replace	6-12 months
		Brush	Clean	1 time/day

			Replace	6-12 months
		Air Filter	Replace	1 time/week
		Dust Bag	Replace	1 time/week
		Front Rubber Strip	Replace	6-12 months
		Rear Rubber Strip	Replace	6-12 months

(The replacement timing for the aforementioned consumables can be determined by referring to the "Consumables" status page on the robot's status screen.)

5.3 Troubleshooting

Fault	Troubleshooting Steps
Unable to power on	<ol style="list-style-type: none"> 1. Check if the robot's battery is too low, and use the power adapter to charge the robot; 2. If the power adapter cannot charge, the battery may be exhausted (left for more than 30 days), take out the battery and use the battery direct charging cable to charge the battery.
Unable to sweep garbage	<ol style="list-style-type: none"> 1. Check if the dustbin is full. If so, pull out the dustbin and empty the debris before proceeding operation. 2. For heavier debris, the side brush gear can be adjusted to "Powerful" mode.
Garbage being scattered	If the debris is lightweight and being blown away by the airflow from the side brushes, the side brush gear can be adjusted to "Eco" mode.

After-Sales Policy

Shenzhen Pudu Technology Co., Ltd. promises to provide free product warranty services starting from the date of product activation within the valid warranty period (warranty periods may vary for different components), and customers are not required to pay after-sales service fees. For cases exceeding the

warranty period or not falling under the free warranty service, fees will be charged according to standard prices. Customers should contact the official after-sales service hotline to arrange repairs.

Pudu Technology will provide warranty service if the following conditions are met::

1、 Within the product warranty period:

- 1) Non-human quality issues occur under normal use.
- 2) No unauthorized disassembly or repair; no water or foreign object ingress; no collision or drop.
- 3) The product serial number, factory labels, and other markings show no signs of tearing or tampering.
- 4) Valid proof of purchase, receipts, and order numbers are provided.
- 5) Damaged spare parts replaced during the warranty period belong to Pudu Technology.

2、 Pudu Technology will charge for repairs in any of the following situations:

- 1) The product exceeds the warranty period.
- 2) The product serial number, factory labels, or other markings are torn, tampered with, or unrecognizable.
- 3) Quality issues caused by collisions or burning not resulting from the product's own quality, or ingress of foreign objects (water, oil, sand, etc.).
- 4) Damage caused by unauthorized modification, disassembly, opening of the shell, or repairs not guided by official instructions.
- 5) Damage caused by incorrect installation, use, charging, or storage not in accordance with the product manual and installation guide.
- 6) Damage caused by using cleaning detergents not specified in official instructions.
- 7) Failure of accessories or components other than the main warranty parts.
- 8) Faults or damage caused by force majeure (such as earthquakes, fires, or wars).

After-sales Service Consultation:

If you have any questions, please contact Pudu Technology Headquarters:

Official After-sales Email: techservice@pudutech.com

Official After-sales Hotline: 400-0826-660